

FINAL REPORT

FATALITY ON BOARD SRS NYK ISABEL IN BUSAN ANCHORAGE, SOUTH KOREA ON 4 MAY 2019

MIB/MAI/CAS.064

**Transport Safety Investigation Bureau
Ministry of Transport
Singapore**

21 October 2020

The Transport Safety Investigation Bureau

The Transport Safety Investigation Bureau (TSIB) is the air, marine and rail accidents and incidents investigation authority in Singapore. Its mission is to promote transport safety through the conduct of independent investigations into air, marine and rail accidents and incidents.

The TSIB conducts marine safety investigations in accordance with the Casualty Investigation Code under SOLAS Regulation XI-1/6 adopted by the International Maritime Organisation (IMO) Resolution MSC 255 (84).

The sole objective of TSIB's marine safety investigations is the prevention of marine accidents and incidents. The safety investigations do not seek to apportion blame or liability. Accordingly, TSIB reports should not be used to assign blame or determine liability.

CONTENTS

SYNOPSIS.....	1
1 FACTUAL INFORMATION	4
1.1 Sequence of events	4
1.2 Photographs of shipboard cranes	6
1.3 Statutory surveys of cranes by Classification Society	9
1.4 Inspection, maintenance records of crane and its operations	9
1.5 Crew experience and rest hours	14
1.6 Additional information obtained from the crane manufacturer.....	15
1.7 Design of the crane cabin (floor plate and the seat).....	18
2 ANALYSIS.....	21
2.1 The Occurrence	21
2.2 Corrosion fatigue and preventive mitigations	21
2.3 Pre incident inspection and maintenance	22
2.4 Design of the Cabin	24
3 CONCLUSIONS	25
4 SAFETY ACTIONS.....	27
4.1 Taken by the Company	27
4.2 Taken by the crane manufacturer	28
5 SAFETY RECOMMENDATIONS	29
5.1 For the Company	29
5.2 For the crane manufacturer.....	29

SYNOPSIS

On 4 May 2019 at about 1750H, a crew fell 20m down from the shipboard crane cabin to the cross deck, when the crew was about to operate the crane, and was seriously injured. The crew was conveyed ashore for medical treatment by the Coast Guard but later succumbed to injuries at the hospital.

The TSIB classified the occurrence as a very serious marine casualty and launched an investigation.

The investigation revealed that the crane cabin's floor plate gave way which caused the crew to fall. The floor plate (as a part of the crane cabin floor) was found corroded with severe pitting along the welded joint which had thinned the material.

The Company's Planned Maintenance System (PMS) incorporated a quarterly inspection schedule recommended by the crane manufacturer. The crew who conducted the inspections, and operators of the crane, did not notice the corruptions of the floor plate over a period of time. The crane manufacturer deemed such inspections to only be carried out by their authorised and trained personnel. The crane manufacturer had not included the scope of inspection required for the crane cabin, including what was to be inspected and how the inspection was to be carried out. The Company stated its difficulties in arranging the crane manufacturer's attendance due to operational constraints.

The investigation revealed that about three years before the incident, the crane manufacturer provided a quote for the replacement of some window frames following its representative's inspection on the affected crane cabin, indicating water ingress from broken window seals but did not specify the consequential risk if the frames were not replaced. The report did not contain information whether the cabin floor or the floor plate was inspected, as the corrosion of the cabin floor (as a whole) was not visible or apparent at the time of inspection. The Company also did not see the urgency for these replacements at that time.

The design of the crane cabin required the operator to stand on the floor plate, albeit temporarily, adding weight on the plate which posed a risk to the operator, especially when the floor plate was corroded. The investigation team thus opined that the design of the crane cabin could be improved by providing additional load bearing support for the floor plate and on the design of the seat arrangement.

DETAILS OF VESSEL

Name	NYK Isabel
IMO Number	9387437
International Call Sign	9VFC3
Flag Registry	Singapore
Classification Society / ISM¹ Recognised Organisation	Nippon Kaiji Kyokai (ClassNK) / DNV-GL
Ship type	Container ship
Year Built	2008
Owner	Mercurius Shipping Pte.Ltd.
ISM Company	Anglo-Eastern Ship Management Ltd. (Hong Kong)
Crane Manufacturer	Liebherr-MCCtec Rostock GmbH
Crane Cabin Manufacturer²	KML Miller GmbH
Crew List³	10 Officers/ 12 Ratings/ 2 Cadets
Gross tonnage	27003
Length overall	210.00m
Draught	7.6m (Fwd) / 7.80m (Aft)

¹ International Management Code for the Safe Operation of Ships and for Pollution Prevention – Under which the ISM Company is the legal entity managing the vessel in compliance with the ISM and ISPS Codes, as required by the Flag Administration.

² According to the crane manufacturer, the crane cabins were supplied by a third-party supplier which was in liquidation (at the time of evidence gathering).

³ All officers and ratings held valid statutory certificates for their position under the STCW Convention.

VIEW OF VESSEL



MV NYK Isabel – annotated by TSIB
Source: MarineTraffic

1 FACTUAL INFORMATION

All times used in this report are Local Time (UTC +9.0H).

1.1 Sequence of events

1.1.1 On 4 May 2019 at about 0505H, NYK Isabel (ISB) was anchored at the harbour anchorage in Busan, Korea, awaiting berthing arrangements.

1.1.2 In fair weather conditions, after routine maintenance work by the crew on the pulley block of ISB's cranes at about 1730H, the Chief Officer (CO) tasked the deck cadet (DC), an able seafarer-deck (ASD1) and an ordinary seaman (OS) to park the cranes to their stowed positions.

1.1.3 The OS was tasked to operate⁴ no.2 crane and the ASD1 to operate no.3 crane. The DC was assigned⁵ for securing the crane blocks of each crane to the main deck. After both the OS and ASD1 had ascended to their respective crane cabin using the fixed vertical ladder, the DC informed (via walkie-talkie) the OS to lower the crane block for no.2 crane to be secured, and also informed the ASD1 to standby for instructions.

1.1.4 After securing no.2 crane block, the DC radioed the ASD1 to lower down the crane block of no.3 crane but did not receive any replies after two calls. The OS also radioed the ASD1 but did not receive a response.

1.1.5 Both the DC and OS then made their way towards no.3 crane and found the ASD1 lying motionless below the crane, on the cross deck. Looking up, they saw that the floor plate of the crane cabin had broken off and hanging from the frame of the crane cabin⁶ (see **figure 1**).

⁴ In accordance with the Company's established processes, the crew had undergone requisite training for operating the crane and were designated as crane operators.

⁵ Also performing the role of a signaller to direct the movement of the crane using radio communications and/or hand signals to the crane operator.

⁶ Distance from the floor plate to the cross deck was about 20m. The cross deck to the main deck was about 1.2m.



Figure 1: (Left picture) No.3 crane with dislodged floor plate shown with yellow arrow (right picture) location (cross deck) where the body of ASD1 was discovered

1.1.6 They immediately informed the bridge of the accident which was further reported to the Master. The CO, Second Officer and another able seafarer-deck (ASD2) arrived at the scene within 2-3 minutes. Together with the DC and OS, they lifted the ASD1 from the cross deck using a stretcher to the main deck. The ASD1 was observed to have weak breathing and was bleeding from the mouth, ear and nose. The crew began administering Cardio Pulmonary Resuscitation (CPR) and provided the ASD1 with medical oxygen. The Master meanwhile requested for medical evacuation after contacting the local authorities and Busan Coast Guard.

1.1.7 The Coast Guard arrived at about 1810H and the ASD1 was conveyed ashore for medical treatment. However, the ASD1 succumbed to the injuries at the hospital.

1.2 Photographs of shipboard cranes

1.2.1 Immediately after the incident, the Master took photographs of the crane cabin for no.3 crane (**figure 2**).

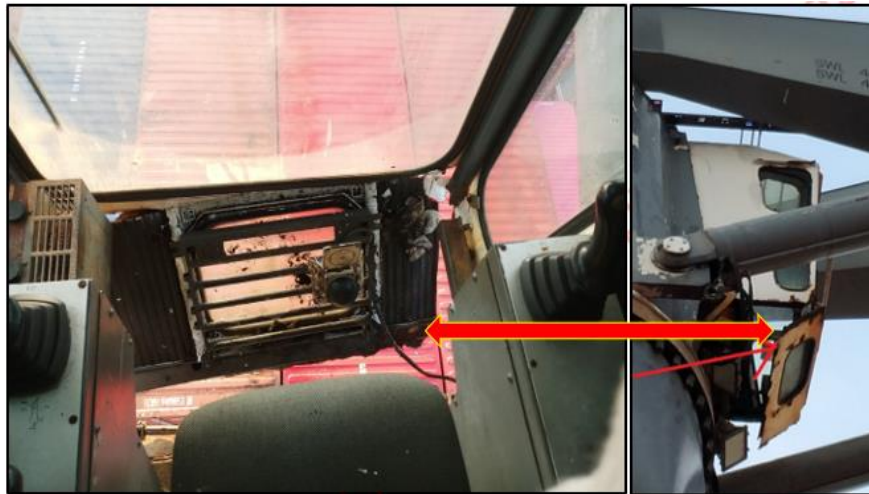

Figure 2: Photographs taken on the day of occurrence showing the broken-off portion (hanging) of the floor plate of no.3 crane cabin

1.2.2 On 5 May 2019, the Company instructed the Master to conduct a check on the condition of remaining crane cabins on board. Similar instructions were provided to all vessels in their fleet. **Figure 3** show the conditions of the floor plate in each respective crane cabin on board ISB. The floor plate was a part of the whole cabin's floor.



Figure 3: Condition of the floor plate taken from inside the cabin for each respective crane cabin. (clockwise from top left) – crane no.1, no.2, no.3 and no.4

1.2.3 Subsequently, on behalf of TSIB, investigators from the Korean Maritime Safety Tribunal (KMST) boarded the vessel (when ISB was berthed alongside a container terminal) and obtained additional photographic evidence on the conditions of the four cranes (see **figures 4a-4d.**)



Figure 4a: Exterior of crane no.1 showing some corrosion on the floor plate



Figure 4b: External and internal photographs of crane no.2. Severe corrosion on the right-hand-side of the floor plate which had separated from the main cabin frame (red arrows). These photographs were taken after the rubber mats were removed and the area was de-rusted by the crew. Inspection platform (green arrow) – details in paragraph 1.5.6



Figure 4c: External and internal photographs of crane no.3 cabin (clockwise from top-left) - the corroded condition of the floor plate, the sheared off right-side portion of the floor plate, and the plan view of the sheared floor plate



Figure 4d: External photograph of crane no.4 cabin displaying condition of the floor plate

1.3 Statutory surveys of cranes by Classification Society

1.3.1 Since 2008, ISB had undergone 12 annual and two five-yearly surveys (by the same classification society), the last recorded examination of the cranes under survey being 19 November 2018.

1.3.2 The classification society's "Rules for Cargo Handling Appliances (updated 2018)" requires a visual examination of cranes to ascertain that they were in good order. While the inspection requirements included structural members, crane cabins were not considered as a structural member and hence did not fall under the purview of such examinations.

1.4 Inspection, maintenance records of crane and its operations

1.4.1 In accordance with the PMS⁷, the steel structure, welds, brackets, ladders and platforms were to be inspected 3-monthly (see **figure 5**). There was no specific inspection requirement for crane cabins. The PMS records indicated that these

⁷ Planned Maintenance System – implemented to comply with requirements of the ISM Code, which ensures timely maintenance is carried out in accordance with statutory requirements.

items (referred to the crane) were checked off in the system by the CO⁸ on 7 March 2019. Although the PMS had a provision to add photographs taken during these inspections, there were no explicit instructions to upload these photographs.

Cranes Cargo Crane No. 3	Check Steel Structure	Check		07-Mar-2019	07-Jun-2019	3 M	C/O
Cranes Cargo Crane No. 3	Crutches	Inspection		06-Apr-2019	06-May-2019	1 M	C/O
Cranes Cargo Crane No. 3	Greasing Points	Grease		30-Mar-2019	30-Apr-2019	1 M	C/O

Last Work Done

CHECKED ALL STEEL STRUCTURE,WELDS,BRACKETS,LADDER AND PLATFORMS. SATISFACTORY.

CHECK STEEL STRUCTURE, WELDS, BRACKETS, LADDERS & PLATFORMS.

Figure 5: Relevant extract from the PMS records. There was no specific inspection requirement for crane cabins.

- 1.4.2 Shipboard records indicated that the no.3 crane was last used⁹ for cargo operations (for loading/ discharging containers) about four years before the incident. However, the Company clarified that at every port, all the shipboard cranes were unparked, swung (to the sea-side) and parked, depending on the positions of the quay cranes ashore to facilitate cargo operations. There were no specific records maintained to indicate when the crew would enter the crane cabin during these times.
- 1.4.3 According to the Company, preceding the occurrence, regular maintenance work on no.3 crane involved the crane block, the hook and the luffing cylinder. Additionally, as a part of a typical corrosion prevention regime on board a ship,

⁸ There were no specific training requirements for carrying out these checks. The CO on board ISB at the time of occurrence had not conducted this inspection since joining, as the next check was due in June 2019.

⁹ The crane manufacturer informed the investigation team, according to the operating manual, if a crane was not in operation for three months, it must be preserved in accordance with the instructions available from the crane manufacturer.

general cleaning and painting for all four crane cabins¹⁰, and de-rusting and painting for crane columns for no.1, 2 and 3 cranes were carried out¹¹.

1.4.4 The operating manual (a copy of which was available on board) stipulated the areas of responsibility (of the crane operator or authorised person) on cleanliness and maintenance, in addition to operating instructions –

- The machines are to be serviced and maintained at prescribed intervals
- To keep the operator’s cabin, windshield, platforms and steps clean
- Keep the windows of the operator’s cabin clean, free of condensation and ice

1.4.5 A table of maintenance schedule from the operating manual is captured in figure 6. According to this schedule, the steel structure, welds, brackets, ladders and platforms should be inspected by the crane manufacturer’s representative. On being asked whether there was guidance¹² available in the operating manual on how the inspections for crane cabins should be carried out by ship’s crew, the crane manufacturer informed the investigation team that inspections and subsequent maintenance of crane cabins should only be carried out by authorised and trained personnel, as it was not possible to include all components in detail.

1.4.6 The Company stated its difficulties in arranging the crane manufacturer’s attendance for inspections at prescribed intervals reflected in the operating manual’s maintenance schedule, due to operational constraints.

¹⁰ The crane manufacturer was not aware of any maintenance on the crane cabins prior to the occurrence.

¹¹ There was no documentary evidence for the condition of the crane cabins prior to this scope of work. According to the crane manufacturer’s communication with the investigation team, if the corrosion or condition of the crane cabins was made known to the crane manufacturer at the time, a complete replacement of the crane cabin would have been recommended, in accordance with the procedures of how other cases of heavy corrosion were handled.

¹²E.g. specific areas to be checked for corrosion in the crane cabin, instructions to lift inspection panels, and removal of rubber mat.

GENERAL MAINTENANCE								
10 h / daily	50 h / weekly	100 h / 2 weeks	250 h	500 h / 3 months	1000 h / 6 months	2000 h / every year		
						O	Check function and correct indication of all control devices	
X							Check correct function of emergency stops	
	X						Check cables and plug connection of main sensors	
				X			Check correct function of lighting	
				X			Check screw connections, brushes of slipping unit	LS
				X			Check-up of steel structure, welds, brackets, ladders, platforms	LS
			X				Drive all functions, check safety devices and limit switches	
						O	Check all terminals and ventilation of switch cabinet	LS
						O	Check junction boxes	
						X	Check correct fit of cables and sensors	
						X	Replace air filter of switch cabinet	

Figure 6: The table of maintenance schedule – specifying the items to be checked.

- 1.4.7 An inspection platform (annotated by a green arrow in **figure 4b**) is fixed on the base column for all cranes. According to the crane manufacturer, this inspection platform was to be used for a visual inspection which could be carried out with simple means. To facilitate a close-up inspection from the outside, the crane had to be swivelled over this platform.
- 1.4.8 According to the operating manual, a portable ladder¹³ was then to be mounted on the crane column by authorised and trained personnel to access the inspection platform (see **figure 7**).
- 1.4.9 The investigation team also noted the Company’s views of this portable ladder being unsafe for its crew to access the inspection platform and thus an external inspection using this platform had not been carried out by the ship’s crew.

¹³ Chapter 7 – Maintenance -. The ladder must be secured against falling down. To mount this ladder a series of steps were to be followed – a) lift ladder by use of an auxiliary rope, up to the slewing column; b) put lower part of the ladder over the slewing ring bolts ensure correct fit of the ladder between the slewing ring bolts; c) remove the ladder always after maintenance works. Any work on top of the slewing column must be executed with a suitable safety fall stop system.

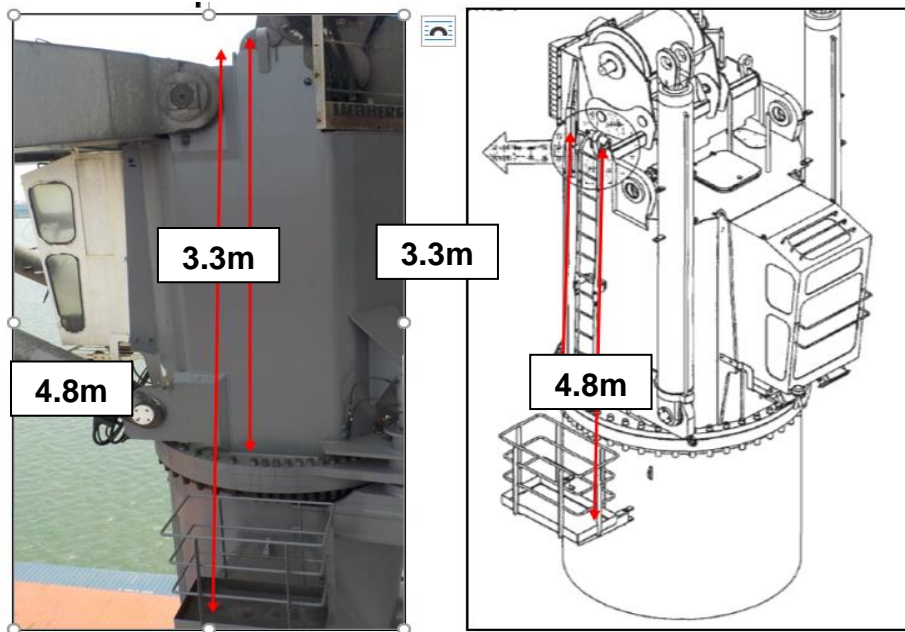

Figure 7: Image on the left shows the location where the portable ladder was to be mounted. Image on the right shows how the portable ladder was to be mounted –
Source: The Company

1.5 Crew experience and rest hours

1.5.1 ISB was manned with a crew of 24 officers and ratings. The crew experience matrix of those involved is shown in the table below.

Designation	Master	CO	DC
Qualification	Deck Officer Class 1 STCW II/2 Issued 2015	Deck Officer Class 2 STCW II/2 Issued 2016	Pre-sea deck cadet course (Diploma)
Certification Authority	United Kingdom	India	India
Nationality	Sri Lankan	Indian	Indian
Age	42	34	21
Experience in Rank	1 year 3 months	1 year	5 months
Period with Company	9 years 3 months	10 months	5 months
Period onboard	1 month	1 month	5 months
Designation	OS	ASD1 ¹⁴	
Qualification	STCW II/4 Issued 2018	STCW II/5 Issued 2016	
Certification Authority	India	India	
Nationality	Indian	Indian	
Age	24	35	
Experience in Rank	3 months	5 years 9 months	
Period with Company	1 year	4 years 5 months	
Period onboard	3 months	3 months	

1.5.2 According to the record of rest hours¹⁵ kept on board, the ASD1 was on bridge watchkeeping duties from 0001H to around 0430H on 4 May 2019. The ASD1 had been on day-work shift on the day of the occurrence from 1030H till the time of occurrence, with an hour's meal break from about 1230H to 1330H. The hours of rest for the preceding 7-day period indicated that the ASD1 had a total of 105 hours of rest.

¹⁴ Was medically fit as per pre-joining medical examination report and weighed about 87kg.

¹⁵ STCW Chapter VIII and MLC, Reg 2.3 with regards to rest hour - Minimum hours of rest shall not be less than i) ten hours in any 24-hour period; and ii) 77 hours in any seven-day period. Hours of rest may be divided into no more than two periods, one of which shall be at least six hours in length, and the interval between consecutive periods of rest shall not exceed 14 hours.

1.6 Additional information obtained from the crane manufacturer

1.6.1 After the incident, the crane manufacturer was provided with photographs of no.3 crane cabin by the Company on 5 May 2019. These photographs were collated and documented by the crane manufacturer and a copy was then provided to the Company. The investigation team obtained this document from the crane manufacturer which contained some photographs and comments¹⁶ (see **figure 8**).

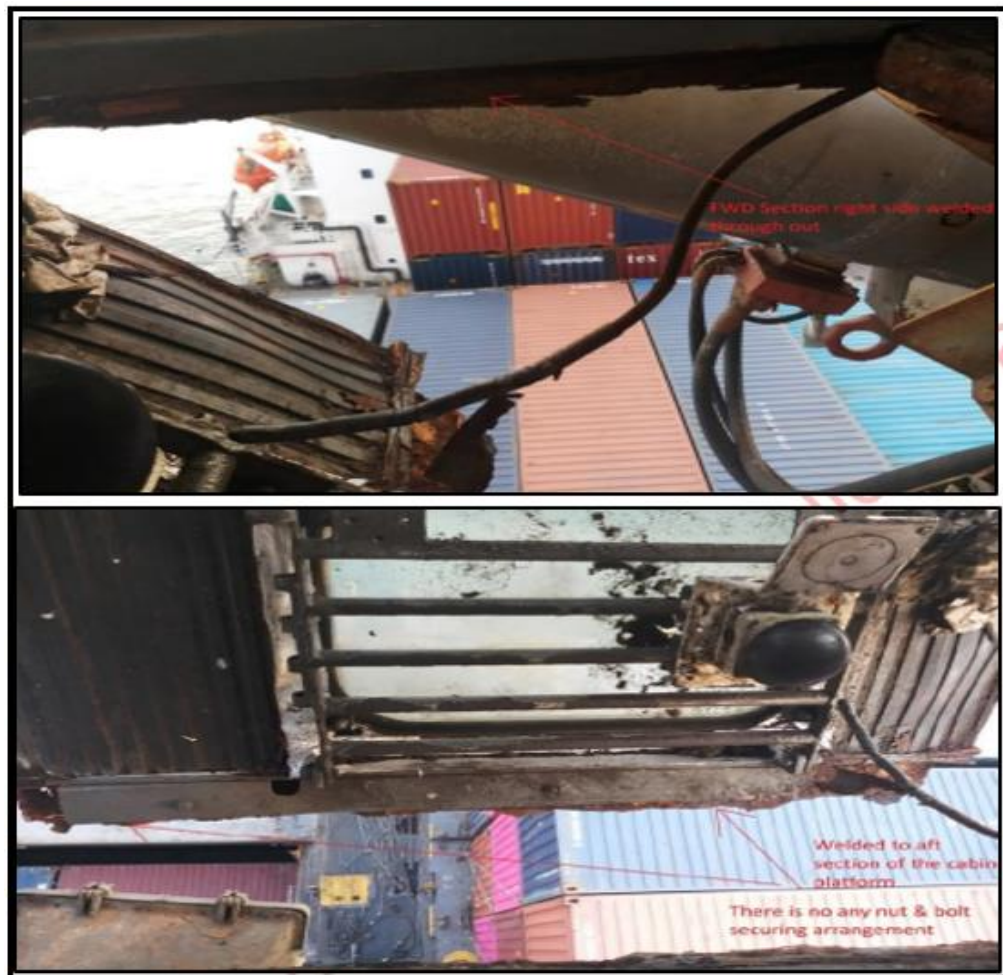

Figure 8: Internal photographs of no.3 crane cabin's floor plate contained in the document – annotations from the manufacturer

¹⁶ The floor plate had sheared off from the welding joint.

1.6.2 The document stated that the floor plate was welded to the aft section of the cabin floor . The document further stated that corrosion along this welded joint(s) of the floor plate of the crane cabin was the cause for the thinning of the original uniformed thickness (3mm) and thus a weakened material.

1.6.3 The investigation team also obtained a copy¹⁷ of the inspection report from the crane manufacturer (dated 23 October 2016) which documented photographs and comments on the conditions of the cabin of no.3 crane. The report documented that corrosion was evident on the hook, block, swivel, hoist motor, lowering brake, doors, hatches and windows (see **figures 9a** and **9b**). All four cranes had badly corroded doors, hatches and window frames. The inspection report did not contain information on the condition of the cabin floor, especially the floor plate and whether these had been inspected.

7. condition of general items :						
hook block and swivel	<input checked="" type="checkbox"/>	rusty / latch not active	<input checked="" type="checkbox"/>	rusty / latch not active	<input checked="" type="checkbox"/>	rusty / latch not active
main motor suspension	<input checked="" type="checkbox"/>		<input checked="" type="checkbox"/>		<input checked="" type="checkbox"/>	
main motor coupling	<input checked="" type="checkbox"/>		<input checked="" type="checkbox"/>		<input checked="" type="checkbox"/>	
boom hinge pins / bearings	<input checked="" type="checkbox"/>	dry not greased	<input checked="" type="checkbox"/>	dry, not greased	<input checked="" type="checkbox"/>	
slew gears / pinions	<input checked="" type="checkbox"/>		<input checked="" type="checkbox"/>		<input checked="" type="checkbox"/>	
hoist motor lowering brake	<input checked="" type="checkbox"/>	rotated	<input checked="" type="checkbox"/>	rotated	<input checked="" type="checkbox"/>	
doors, hatches, windows	<input checked="" type="checkbox"/>	door corroded badly	<input checked="" type="checkbox"/>	windows corroded badly	<input checked="" type="checkbox"/>	windows corroded badly

Figure 9a: Extracts of the inspection report dated 23 October 2016, conducted by the crane manufacturer – handwritten notes refer to cranes no.1 to 4 from left to right

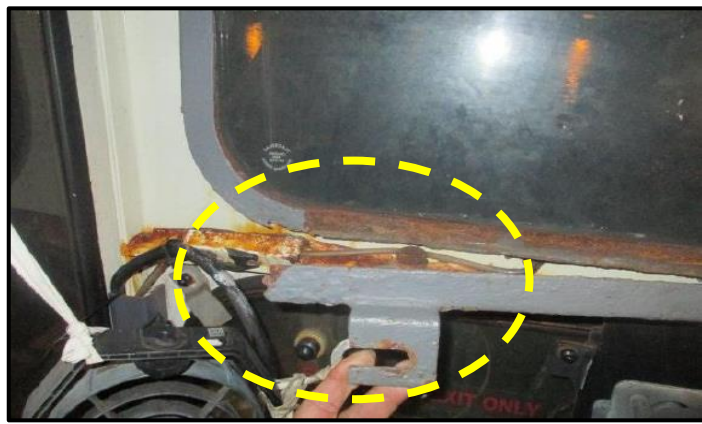

Figure 9b: The corroded window seal and locking frame during the inspection in October 2016 (circled yellow by TSIB)

¹⁷ The Company was provided a copy of this report by the manufacturer.

1.6.4 Following the inspection report on all the cranes, the crane manufacturer proposed some repairs to the Company, dated 17 November 2016, including the repairs to be done on the cabin for no.3 crane, which included replacing some frames of the cabin (see **Figure 10**).



Figure 10: Extracts of the repair invoice dated 17 November 2016 offered to the Company by the crane manufacturer on the replacements of the (window) frames. Red arrows annotated by the crane manufacturer for the investigation team – Source: crane manufacturer.

1.6.5 The Company, on the other hand, expressed that there was no mention of a consequential risk if the frames were not replaced and confirmed that there was no quote for a crane cabin, as a whole. The Company further confirmed that even if the frames were replaced, there would be no change to the existing floor plate and that replacing the floor plate would typically be only performed in a drydock in consultation with the crane manufacturer.

- 1.6.6 When asked, the crane manufacturer clarified that corrosion of the cabin floor (as a whole) was not visible or apparent at the time of inspection in 2016 and thus the quote was only for the frames.
- 1.6.7 About two months after the incident, the crane manufacturer issued a service bulletin for its clients¹⁸, regarding corroded cabins on older cranes, drawing the attention to the table of maintenance schedule (see **figure 6**) recommended in the operating manual, highlighting that corrosion could form internally due to condensation, as well as from ingress of water from broken window seals.
- 1.6.8 This service bulletin further stated (additional information) that the entire machine should also be checked for mechanical damage and corrosion every 1000 hours/ six-monthly, and if any damage due to corrosion found during the inspections, the crane manufacturer should be contacted without undue delay to take appropriate protective or counter measures.
- 1.7 Design of the crane cabin (floor plate and the seat)
- 1.7.1 The crane operator would enter the cabin from the rear after climbing a series of vertical ladders affixed within the crane structure. Upon entering the cabin while preparing for crane operations, the seat needed to be lifted sideway to the right (facing forward) for the operator to move to the forward part of the cabin and stand on the floor plate (which has gratings on top of the viewing glass) temporarily, before putting the seat down and be seated (see **figure 11**).

¹⁸ In the crane manufacturer's record, about 1890 units of similar ship cranes with the same maker's crane cabin were sold.

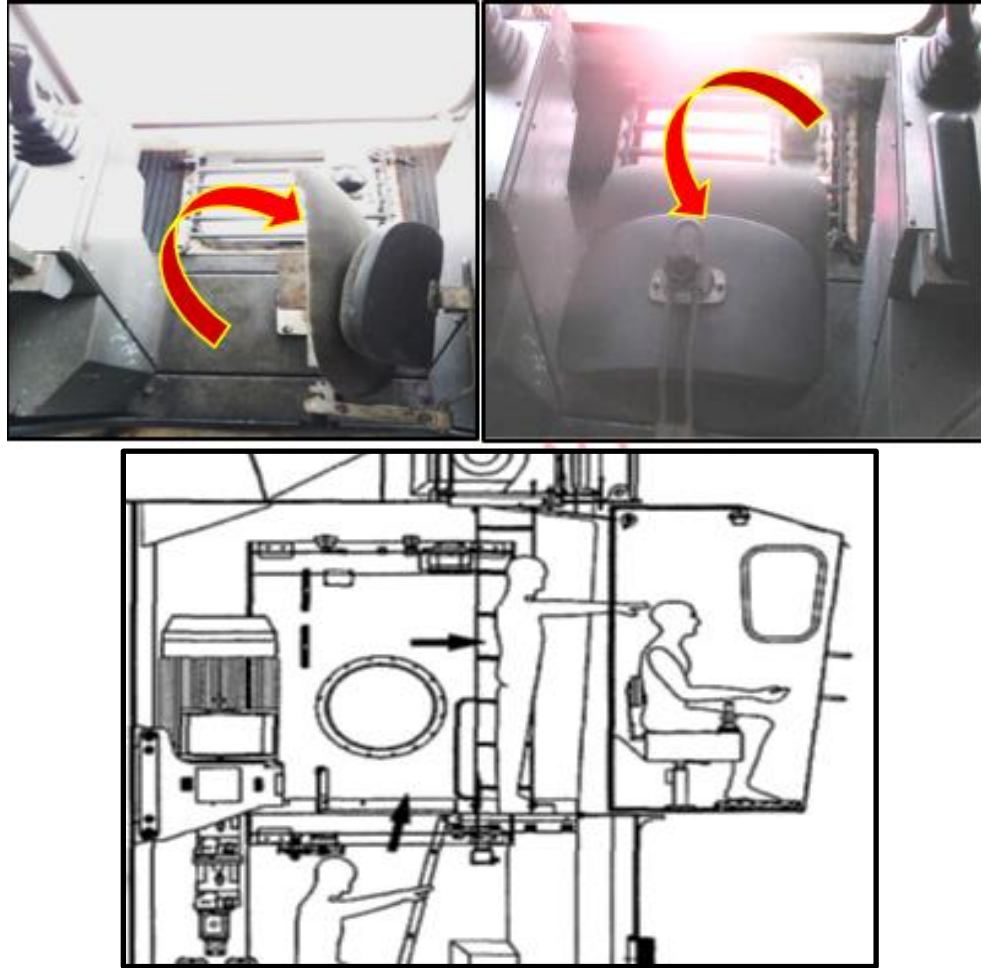

Figure 11: (Top left picture) seat lifted sideway for operator to move forward, (Top right picture) seat put down for the operator to be seated, (bottom picture) operator entering the cabin from the rear and seated for operating the crane – annotated by TSIB

- 1.7.2 The design of the crane cabin on ISB was outsourced by the crane manufacturer to a third party¹⁹. The new cabins supplied to ISB after the occurrence had the same seat design.
- 1.7.3 A removable panel on the crane cabin's floor could be lifted up (see **figure 12**) to inspect the welded joint (partial) of the floor plate. The operating manual did not state the need for using the removable panel to inspect for corrosion. There were no specific signs, notice or markings inside the cabin to indicate the

¹⁹ The crane manufacturer did not have specific expertise in the design of crane cabins, and thus chose a supplier specialised and experienced in the field of design and supply of crane cabins for maritime applications.

purpose of this panel. It could not be established whether the inspection during the 3-monthly checks by the CO had utilised this panel.

- 1.7.4 The edges of the cabin from where the floor plate gave way were covered by rubber mats which had been glued. There was no requirement stated in the operating manual or any notices inside the cabin for the removal of these mats to check for corrosion or trapped water along the edges.



Figure 12: The red arrow shows the access for the removable panel

- 1.7.5 The Company opined that the 3mm thickness of the floor plate was deemed inadequate based on a fleet-wide check on the thickness of the cabin floor of cranes from other crane manufacturers, which was recorded to be at least 6mm.
- 1.7.6 According to the crane manufacturer's records, about 1890 ship cranes had been installed with the same type of cabin having floor plates of the same thickness and that there had been no known incidents of such a failure of the floor plate. The thickness of the floor plate was considered adequate according²⁰ to the crane manufacturer.

²⁰ According to the crane manufacturer, the crane cabin manufacturer was one of the leading suppliers of cabins for cranes for ships and ports.

2 ANALYSIS

2.1 The Occurrence

2.1.1 In the absence of a witness account, the investigation team analysed how the accident might have occurred based on the information gathered, such as statements from the crew, PMS inspection records, crane operating manual, and documents obtained from the manufacturer.

2.1.2 As evident from the photographs of the crane cabin (see **figure 8**) submitted to the manufacturer by the Company after the accident, the welded edges or the crevices of the cabin floor had suffered severe pitting corrosions.

2.1.3 Prior to the occurrence, the ASD1 had likely stood on the floor plate while preparing to sit down to operate the crane. The severely corroded welded joint of the floor plate had weakened its structural integrity which could not take the weight of the ASD1 and gave way. This had resulted in the unsuspecting ASD1 to fall down to the cross deck from a height of about 20m.

2.2 Corrosion fatigue and preventive mitigations

2.2.1 Under conditions at sea, metal structures on board a vessel is susceptible to a faster rate of corrosion due to the high salt content. Hence, regular inspections and maintenance, such as derusting and repainting, have been a routine practice to prevent metal structures from corrosion.

2.2.2 The floor plate which was 3mm in thickness had, as a result of the pitting corrosion, thinned down and weakened at the welded joints. It was highly probable that this deterioration, i.e. severe corrosion at the edges and welded joints had occurred over a long period of time. Since the rubber mats were glued to the cabin floor, the welded joints which were concealed underneath had gone unnoticed, despite the multiple times that various personnel had entered the crane cabin.

2.2.3 Had there been clear guidance available for the removal of the rubber mats for carrying out a detailed inspection, the condensation along the welded edges

might have been noticed. Similarly, the removable panel (see **figure 12**) if labelled could have been used to inspect the condition of the welded joint of the cabin floor.

2.3 Pre incident inspection and maintenance

2.3.1 The inspection of crane cabin was not a statutory requirement under the annual survey. The scope of an inspection by the crane manufacturer was brief in the operating manual, which had also been transposed into the 3-monthly checks (see **figures 5 and 6**) in the PMS. Although the crane manufacturer expected such an inspection to be done by authorised personnel, there were no records of such an inspection of the crane cabin being carried out by the crane manufacturer on board ISB in the period preceding the accident, especially after the inspection in October 2016.

2.3.2 The investigation team opined that, a poor condition of the crane cabin poses a safety hazard to the crane operator. The operating manual should thus be detailed to include the specific inspections (and maintenance) to be carried out at regular intervals. Specifically, to inspect the welded joints, for e.g. by removing the rubber mats²¹, lifting the inspection panel and the need to use the inspection platforms for external close-up visual checks for signs of corrosion. These requirements should also be transposed to the PMS.

2.3.3 The investigation team noted that the Company had performed general cleaning and painting for all four crane cabins by its ship's crew, which is an industry practice for corrosion prevention. All ship's crew are generally equipped with the knowledge and experience to carry out typical corrosion prevention tasks which involve derusting and application of relevant coating and paint. However, the lack of sufficient detail in the scope of an inspection, had likely resulted in the cabin floor being neglected during the 3-monthly inspections and subsequent maintenance by the crew.

2.3.4 Regardless of the scope of the inspection and a follow-up maintenance, noting the views of the crane manufacturer that any inspection/ maintenance on the crane cabins was to be performed by authorised and trained personnel, the

²¹ Including provisions for the rubber mats to be removed easily

- investigation team opined that such a prohibition should have been expressly stated in the operating manual, and accompanied by appropriate notices inside the crane cabin.
- 2.3.5 While the frequency of an inspection of the cranes by the manufacturer was recommended in the operating manual, the investigation team recognised that owing to operational constraints, it may not be possible to have the cranes inspected on a 3-monthly basis by the manufacturer's representative. However, if such a requirement was mandated by the crane manufacturer, and it was not possible for an inspection to be arranged by the manufacturer's representative, arrangements could be made for the Company to provide its own 3-monthly inspection reports to the crane manufacturer for appraisal and a timely intervention.
- 2.3.6 Accordingly, the SMS should also have provided clarity on the scope of this inspection with guidelines (on the need for safe methods for carrying out external close-up visual checks) on how the inspection was to be carried out and to ensure that the requirements to provide photographic evidence were carried out by the ship's crew.
- 2.3.7 The crane manufacturer's inspection report in October 2016 stated possible water ingress from the broken window seal in no.3 crane cabin. However, the report did not indicate whether the welded joints between the floor plate and the cabin main frame had been inspected during that inspection (see paragraph 1.6.3). After the inspection, the crane manufacturer provided a quotation list to the Company which included the frames associated with the crane cabin. There was no accompanying report specifying any consequential risk if these frames were not replaced or the urgency to replace the crane cabin (as a whole) due to the water ingress.
- 2.3.8 The investigation team thus held the view that having a detailed scope of inspection in the operating manual, would not only provide clearer guidance to the manufacturer's representative conducting an inspection, but could also be transposed into the Company's PMS to allow for inspection of an equivalent standard to be applied by the ship's crew.

2.3.9 The preservation requirements in the operating manual (see 1.5.2) was noted by the investigation team, but there was no evidence to suggest that the crane was not in operation as the crane was operated regularly to park and unpark for cargo operations.

2.4 Design of the Cabin

2.4.1 Although the 3mm thickness of the floor plate was deemed sufficient by the crane manufacturer, there was no additional support underneath to act as a secondary barrier in the event it gave way. It was possible that this risk had not been anticipated during the design of the crane cabin. Thus, the investigation team opined that there is merit for the design of the crane cabin to be reviewed.

2.4.2 The design of the seat in the crane cabin was such that it required the operator to get past a lifted seat and stand temporarily on the floor plate. The investigation team opined that while the cabin floor might have been designed to take the load of a person, there was a risk to the operator standing on it, as there was no secondary load bearing support structure underneath the floor plate. Hence, there is room for improvement²² for the design of the crane cabin to avoid a single failure path.

²² One consideration is to have a swivel type seat where the operator gets seated facing aft and swivelled into a forward-facing position. Before sitting on the swivel seat, the operator would be standing on the structure holding the seat, which is much stronger. This would eliminate the risk of standing on the floor plate .

3 CONCLUSIONS

From the information gathered, the following findings, should not be read as apportioning blame or determining liability to any particular organisation or individual.

- 3.1 The fatal occurrence was due to the crane cabin's severely corroded floor plate giving way, which caused the ASD1 to fall to the cross deck when the ASD1 was preparing to operate the crane.
- 3.2 A quarterly inspection by the crane manufacturer was recommended in the operating manual. Although generic maintenance on the cranes was carried out by the ship's crew under the 3-monthly PMS, it did not include the inspection of the crane cabins.
- 3.3 The crane manufacturer's operating manual did not provide a detailed scope of the inspection required for the crane cabin, i.e. inspection of the welded edges underneath the rubber mats or the welded joints with regards to the cabin floor, as the crane manufacturer deemed such inspections were supposed to be carried by its trained and authorised personnel.
- 3.4 Owing to the operation constraints experienced by the Company in arranging an inspection by the crane manufacturer, the crane cabins were not inspected and the thinning of the floor plate in the crane cabin due to corrosion was not noticed over a period of time.
- 3.5 Although the crane manufacturer had provided an inspection report in October 2016, which indicated water ingress from the broken window seal in no.3 crane cabin, the consequential risk if the window frames (which would increase the rate of corrosion within the cabin) or the urgency to replace the crane cabin (as a whole), were not identified.
- 3.6 The design of the cabin should be improved in providing additional load bearing support for the floor plate in view of the current thickness. Similarly, the design of the seat in the crane cabin posed a risk to the operator as it required the operator to stand on the floor plate, where the load is acting on a weaker area as compared to the main crane's structure, before the operator gets seated.

3.7 The PMS had a provision for photographs to be included in the 3-monthly report for the generic maintenance of the cranes. However, photographed records were not maintained to compare any degradation.

4 SAFETY ACTIONS

During the course of the investigation and through discussions with the investigation team²³, the following preventive / corrective action(s) were taken by parties involved.

4.1 Taken by the Company

4.1.1 Added specific instructions in the PMS for areas to be inspected regarding the checks on steel structure for crane(s) including the crane cabin both internally and externally (via the inspection platform). Circulated posters to the fleet specifying the areas of inspection with details including removal of anti-slip mats, and opening of inspection panels, etc. and repairs to be carried out including derusting and painting. Actions taken to be documented in the PMS together with photographs.

4.1.2 Fixed ladders were installed²⁴ (in a shipyard) on the crane columns for the access to the inspection platform from the cross deck (see **figure 13**).



Figure 13: Fixed ladders installed on the cranes in a shipyard (green arrows).

²³ A safety flyer by TSIB was circulated in September 2019 to raise awareness on the importance of carrying out comprehensive inspection of safety barriers such as railings and gratings, with timely preventive maintenance and implementing adequate safeguards in place to ensure safety of personnel on board ships.

²⁴ These actions taken by the Company was not in consultation with the crane manufacturer but were carried out to the satisfaction of the attending Class surveyor.

4.1.3 Crane cabins for crane no.1, 2 and 3 were replaced and the Company installed additional gratings (external) below the cabin, as an added risk mitigation measure (see **figure 14**).

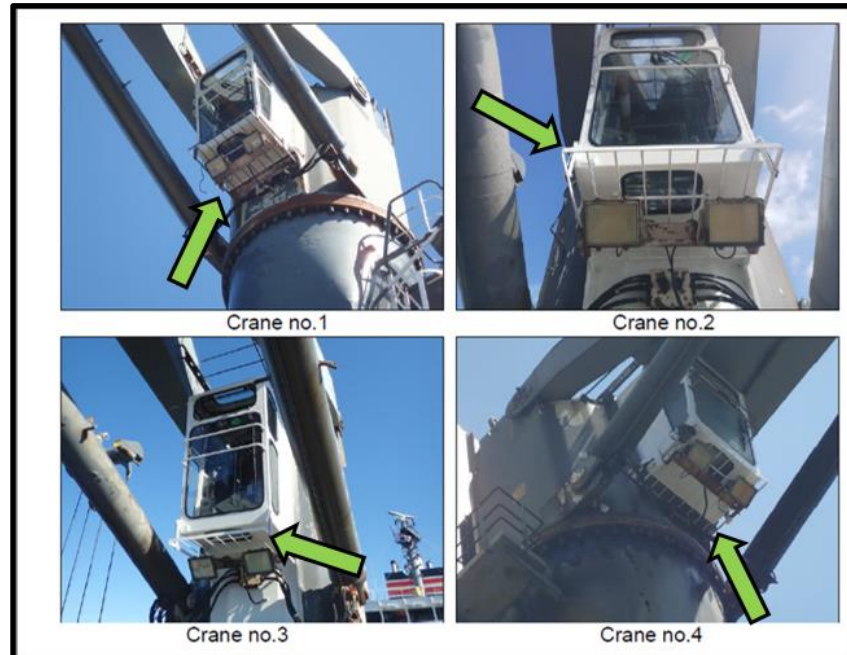

Figure 14: New crane cabins installed on crane no.1, 2 and 3. Cabin bottom gratings were installed by the Company on all four cranes (green arrows).

4.2 Taken by the crane manufacturer

4.2.1 The crane manufacturer issued a service bulletin to all its users highlighting the importance of proper inspection in accordance with the manufacturer's manual to detect corrosion.

5 SAFETY RECOMMENDATIONS

A safety recommendation is for the purpose of preventive action and shall in no case create a presumption of blame or liability.

5.1 For the Company

5.1.1 To consider including a detailed inspection of crane cabins in the SMS, specifying the need to remove rubber mats and inspection panel, to be required in the PMS and to ensure that photographs of these inspected areas are appended in the PMS records. **[TSIB-RM-2020-34]**

5.2 For the crane manufacturer

5.2.1 To consider including the scope of visual inspection for crane cabins in the operating manual with the requirements of removing rubber mats and lifting of inspection panel for corrosion checks . **[TSIB-RM-2020-35]**

5.2.2 To consider a review in the design of the cabin in providing additional support to the cabin floor in view of the floor plate thickness. **[TSIB-RM-2020-36]**

5.2.3 To also consider a review in the design of the seat to minimise the duration the operator stands on the floor plate before being seated. **[TSIB-RM-2020-37]**

End of Report